

## AUTOMATIC SCREWDRIVING MODULAR SYSTEM "SAMOA"

COLUMN SELF-POWERED DRIVING STATION - tilting drawer screws positioning

WATT: 100-480 / RPM: 330 - 4200 / CONSUMPTION: 25-36 NI/ciclo

Data sheet  
**BASCO S A2P**

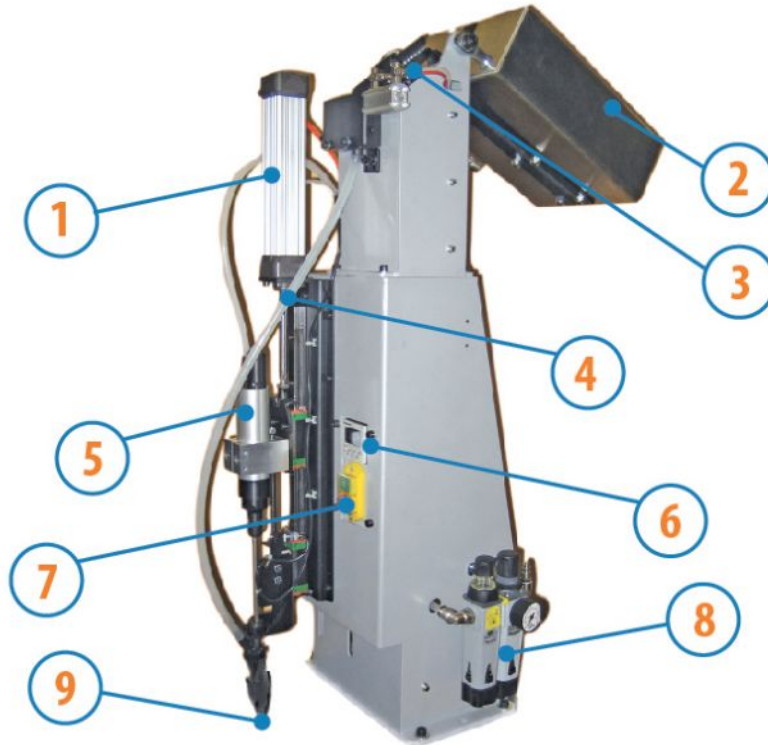

1. Engine piston
2. Pivoting box
3. Screws group selector
4. Screws supply pipe
5. Engine
6. PLC with display
7. Controls
8. Lubricator with pressure regulator
9. Head screw

### Technical specification

|                   |             |
|-------------------|-------------|
| Model             | BASCO S A2P |
| Code              | 8840021     |
| Max stroke - mm   | 40          |
| Length - mm       | 595         |
| Width - mm        | 320         |
| Height - mm       | 1130        |
| Base support - mm | 280 X 215   |

Dimensions of the screws that can be fed with the normal standard equipment (mm)

## AUTOMATIC SCREWDRIVING MODULAR SYSTEM "SAMOA"

COLUMN SELF-POWERED DRIVING STATION - tilting drawer screws  
positioning

WATT: 100-480 / RPM: 330 - 4200 / CONSUMPTION: 25-36 NI/ciclo

### BASCO

|         |           |         |         |         |         |         |          |
|---------|-----------|---------|---------|---------|---------|---------|----------|
| Ø testa | 3,5 - 4,2 | 4 - 5,2 | 5 - 6,5 | 6 - 7,2 | 7 - 8,2 | 8 - 9,2 | 9 - 10,4 |
| Length  | 8 - 25    | 10 - 25 | 12 - 25 | 14 - 25 | 16 - 25 | 18 - 25 | 20 - 40  |

Data sheet  
**BASCO S A2P**